

GPRS Antenna

GPS / GSM or AMPS Antenna

Applications

- GPS / GSM or AMPS antenna
- Permanent mount



Description

Low-profile GPS / GSM or AMPS antenna is a dual purpose mobile antenna. It comes standard with a 5 meter cable, operates on 3-5VDC and has SMA connectors. The combination of a high gain GPS antenna and -1 dBi GSM band antenna is ideal for those applications that require

durability, small size, covert installation and rugged construction. This antenna is specifically designed for fixed location, permanent mount applications. These antennas are waterproof and comply with automotive temperature and vibration standards.

Features:

- Low-profile
- Dual purpose
- High gain GPS antenna
- -1 dBi GSM band antenna
- Small size
- Rugged construction
- Designed for fixed location
- Waterproof

Specifications

Antenna

Frequency	1575 ± 3 MHz
VSWR	1.5 : 2 Max.
Bandwidth	10 MHz Min.
Impedance	50
Gain	27dB typical w/o cable
Gain Coverage	-4 dBic at -90° 90° (over 75% volume)
Power Handling	1 watt
Polarization	RHCP
Noise Figure	1.2 dB Typical
Output VSWR	2.0 Max.
Filtering	-25 dB (± 100 Mhz)
DC Voltage	DC 3 to 5 V
DC Current	22 mA Max.

GPRS Antenna

GPS / GSM or AMPS Antenna



Specifications

Cellular Antenna

Frequency	880 - 960 Mhz (GSM), AMPs or ETACS
VSWR	2.0 : 1
Peak Gain	3 dBi Min.
Polarization	Linear
Pattern Type	Omni-direction

Mechanical

Weight	320 gram
Size	100mm Dia. * 39mm
Cable:	
GPS	RG - 58/U with 5 meter long
Cellular	RG - 174/U with 5 meter long
Connector:	
GPS	SMA (plug)
Cellular	SMA (plug)
Mounting	Thread permanent mount
Housing Color	White

Environmental

Working Temp.	-40° C - +85° C
Storage Temp.	-40° C - +85° C
Vibration	Sine sweep, 1G (0-P), 10-150-10Hz each axis
Humidity	95% - 100% RH
Weatherproof	100% waterproof

*Specifications subject to change without notice.

Part Numbers

P/N 91-430-0

GPRS Antenna

GPS / GSM or AMPS Antenna



Outline Dimensions

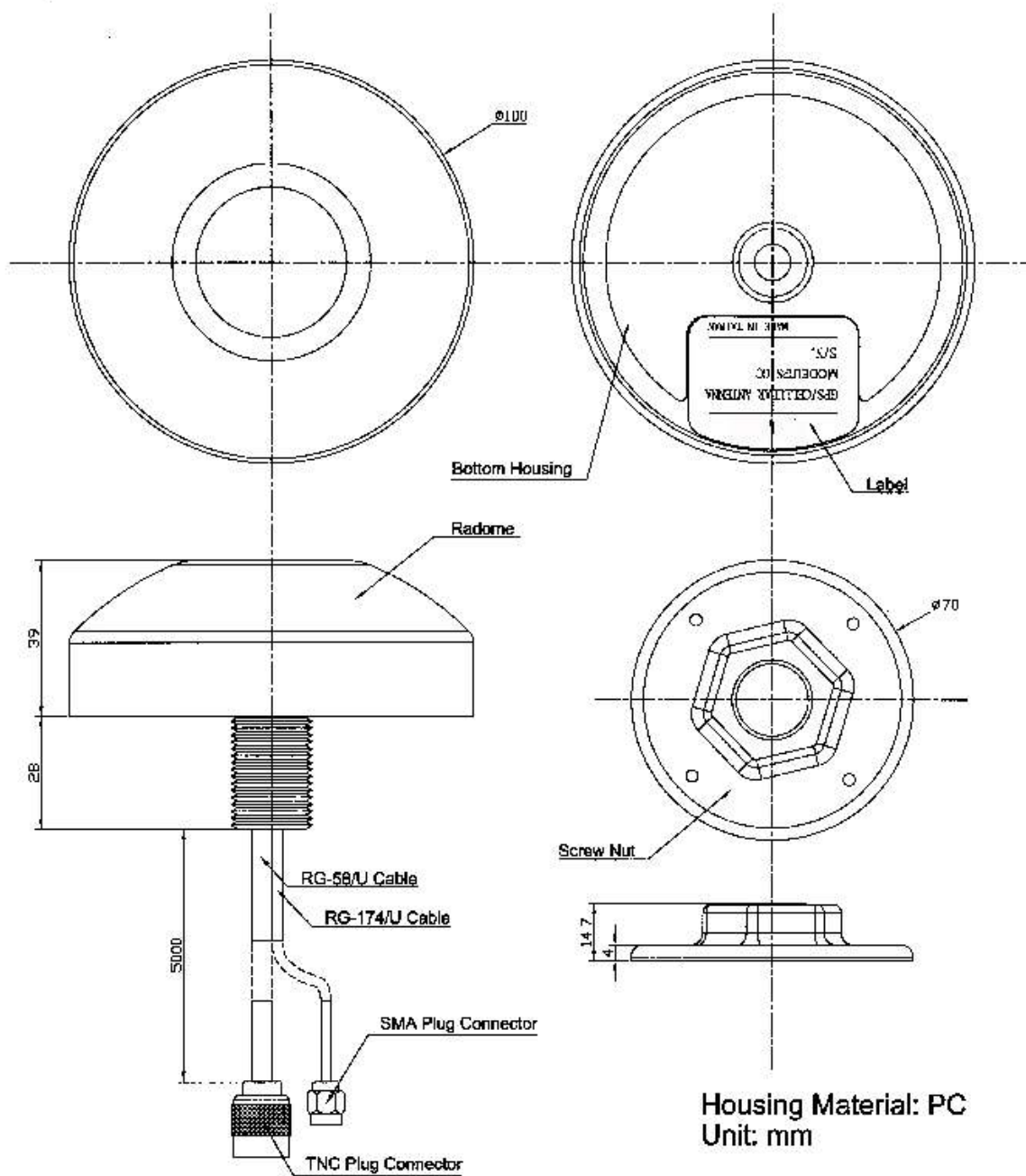

NOTE: Connector available in SMA or TNC style.

LUXCOM Technologies Inc.

102 Walgreen Road, Ottawa, Ontario K0A 1L0 Canada Tel.: +1 (613) 831-7777 Fax: +1 (613) 831-7778

email: sales@luxcom.com

www.luxcom.com